



Technical specifications and instructions



35 Frame Plunger pump

Brass – standard & flushed

3535, 3535C

SS – standard & flushed

3531, 3531C

Nickel aluminum bronze

3537

Specifications (*)

Model 3535 (C) 3531 (C) 3537

Flow	138 L/min
Pressure range	7 to 85 bar
RPM	800 RPM
Inlet pressure range	Flooded to 4,9 bar
Stroke	48 mm

Common specifications

Bore	40 mm
Crankcase capacity	4 L
Maximum liquid temperature	70° C
Inlet ports (2)	1-1/2" NPTF
Flushed ports (2)	1/4" NPTF
Discharge ports (2)	1 NPTF
Shaft diameter	35mm
Weight	63 kg
Dimensions (3535, 3535C)	607 x 460 x 247 mm
Dimensions (3531, 3531C, 3537)	618 x 460 x 247mm

(*) Abnormalities permitted only after consultation and written confirmation from Cat Pumps.

Exploded View

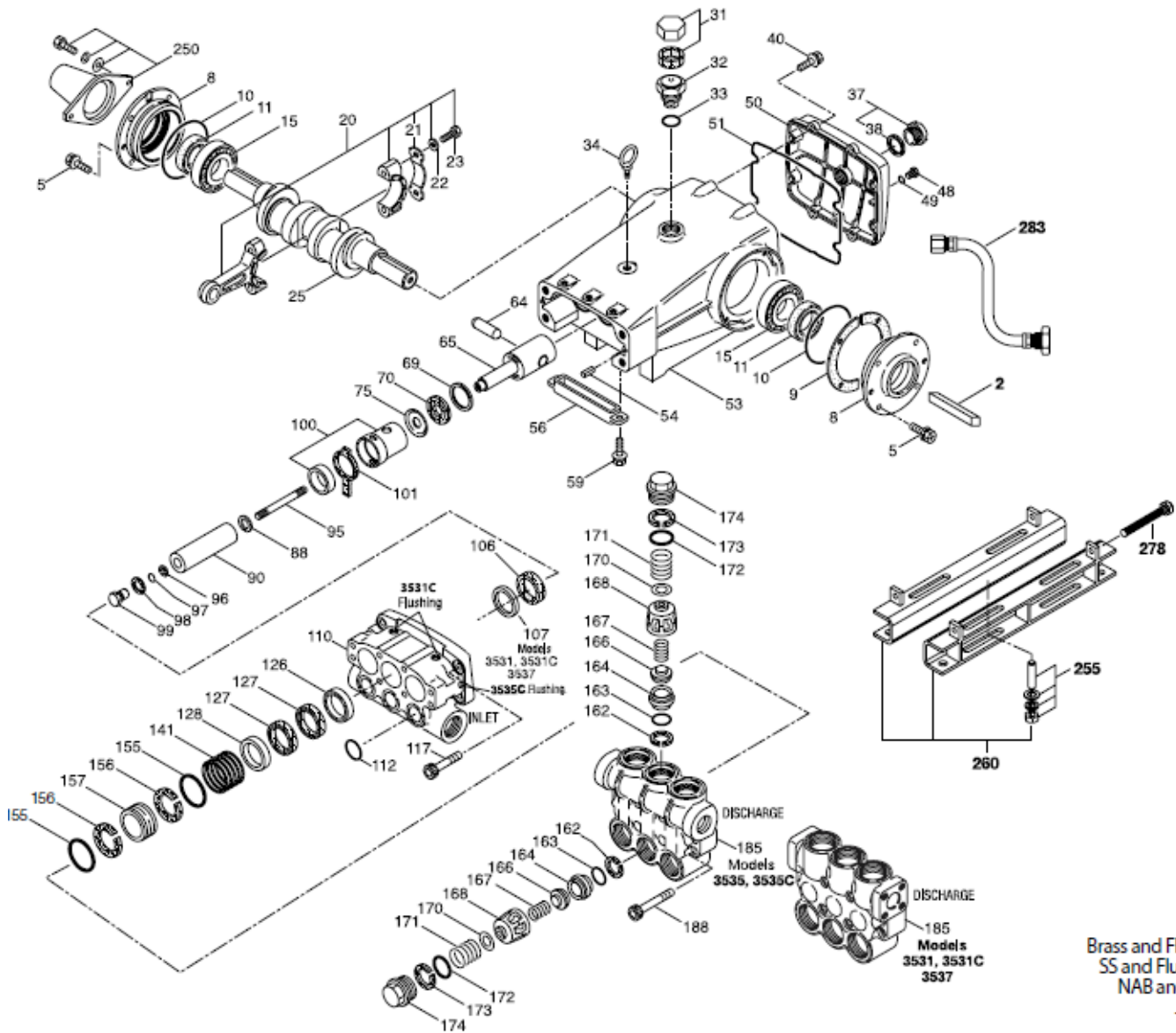

Models
 Brass and Flushed - 3535, 3535C
 SS and Flushed - 3531, 3531C
 NAB and Flushed - 3537
 July 2017

Parts list

lt.	Num. 3535 3535C	Mat.	Num. 3531 3531C	Mat.	Num. 3537	Mat.	Description	Qt
2	34021	STL	34021	STL	34021	STL	Key (M10x8x70)	1
5	125753	S	125753	S	125753	S	Screw, HHC sems (M8x25)	8
8	44542	AL	44542	AL	44542	AL	Cover, bearing (see TB 118)	2
9	815279	FBR	815279	FBR	815279	FBR	Shim, split, 2-pc	2
10	12398	NBR	12398	NBR	12398	NBR	O-ring, bearing cover – 70D	2
11	13296	NBR	13296	NBR	13296	NBR	Seal, oil, crankshaft	2
15	29326	STL	29326	STL	29326	STL	Bearing, roller	2
20	121467	TNM	121467	TNM	121467	TNM	Rod, connecting assy (incl. 21,22,23) {10/00}	3
21	126749	STCP R	126749	STCP R	126749	STCP R	Locking washer (M10)	3
22	126593	STCP R	126593	STCP R	126593	STCP R	Washer, flat (M10.5)	6
23	122045	STZP	122045	STZP	122045	STZP	Screw, HH (M10x55)	6
25	29325	FCM	29325	FCM	29325	FCM	Crankshaft, dual end (M48)	1
31	828710	PE	828710	PE	828710	PE	Protector, oil cap w/gasket	1
32	43211	ABS	43211	ABS	43211	ABS	Cap, oil filler	1
33	14177	NBR	14177	NBR	14177	NBR	O-ring, oil filler cap – 70D	1
34	126743	STCP R	126743	STCP R	126743	STCP R	Bolt, eye (M12x1,75) (for lifting pump only)	1
37	92241	-	92241	-	92241	-	Gauge, oil, bubble w/gasket	1
38	44428	NBR	44428	NBR	44428	NBR	Gasket, flat oil gauge – 80D	1
40	125753	S	125753	S	125753	S	Screw, HHC sems (M8x25)	8
48	25625	STCP	25625	STCP	25625	STCP	Plug, drain (1/4" x 19 BSP)	1
49	23170	NBR	23170	NBR	23170	NBR	O-ring, drain plug – 70D	1
50	45936	AL	45936	AL	45936	AL	Cover, rear (see TB 118)	1
51	16612	NBR	16612	NBR	16612	NBR	O-ring, crankcase cover – 70D	1
53	44487	AL	44487	AL	44487	AL	Crankcase assy (incl. 34,54) (see TB 118)	1
54	27488	S	27488	S	27488	S	Pins, guide	2
56	27790	POP	27790	POP	27790	POP	Pan, oil	1
59	92538	S	92538	S	92538	S	Screw, HHC sems (M6x16)	2
64	43864	CM	43864	CM	43864	CM	Pin, crosshead	3
65	+ 45116	SSZZ	45116	SSZZ	45116	SSZZ	Rod, plunger	3
69	126587	STCP R	126587	STCP R	126587	STCP R	Washer, oil seal	3
70	100488	NBRS	100488	NBRS	100488	NBRS	Seal, oil, crankcase	3
	44739	FPM	44739	FPM	44739	FPM	Seal, oil, crankcase	3
75	43865	S	43865	S	43865	S	Slinger, barrier	3
88	45676	S	45676	S	45676	S	Washer, keyhole (M16)	3
90	43921	CC	43921	CC	43921	CC	Plunger (M40x145)	3
95	+ 89778	SS	89778	SS	89778	SS	Stud, plunger retainer (M10x135)	3
96	20189	PTFE	20189	PTFE	20189	PTFE	Back-up-ring, plunger retainer	3
97	11345	NBR	11345	NBR	11345	NBR	O-ring, plunger retainer – 70D	3
	11375	FPM	11375	FPM	11375	FPM	O-ring, plunger retainer	3
	#701490	EPDM	# 701490	EPDM	# 701490	EPDM	O-ring, plunger retainer	3
98	44085	SS	44085	SS	44085	SS	Gasket, retainer	3
99	+ 44084	SS	44084	SS	44084	SS	Retainer, plunger (M10)	3
100	814279	PVDF	814279	PVDF	814279	PVDF	Retainer, seal, 2-pc (see TB 105)	3
101	44112	-	44112	-	44112	-	Wick, long tab	3
106	+ 44113	NBR	44113	NBR	44113	NBR	Seal, LPS w/SS-spg	3
	44740	FPM	44740	FPM	44740	FPM	Seal, LPS w/SS-spg	3
	# 46955	EPDM	# 46955	EPDM	# 46955	EPDM	Seal, LPS w/SS-spg	3
107	-	-	45381	SS	44115	NAB	Spacer, Lo-pressure seal	3
110	49464	BBCP R	45365	SS	45124	NAB	Manifold, inlet	1
	49464C	BBCP R	125397	SS	-	-	Manifold, inlet, flushed (1/4" flush ports)	1
112	11379	NBR	11379	NBR	11379	NBR	O-ring, inlet manifold – 70D	3
	14183	FPM	14183	FPM	14183	FPM	O-ring, inlet manifold	3
	# 701491	EPDM	# 701491	EPDM	# 701491	EPDM	O-ring, inlet manifold – 70D	3
117	44585	S	44585	S	44585	S	Screw, HSH (M14x40)	4
126	46494	BB	48391	D	48391	D	Adapter, female (see TB 087)	3
	-	-	45367	SS	45367	SS	Adapter, female	3
127	44609	STG	44609	STG	44609	STG	V-packing	6
	44741	SFG	44741	SFG	44741	SFG	V-packing	6
128	43928	BB	45368	SS	45368	SS	Adapter, male	3
141	49519	SS	49519	SS	49519	SS	Spring, large coil (see TB 108)	3

155	48860	NBR	48860	NBR	48860	NBR	O-ring, V-packing spacer – 90D	6
	20137	FPM	20137	FPM	20137	FPM	O-ring, V-packing spacer – 70D	6
	# 701492	EPDM	# 701492	EPDM	# 701492	EPDM	O-ring, V-packing spacer	6
156	48362	D	48362	D	48362	D	Back-up-ring, V-packing spacer	6
157	49478	BB	49520	SS	49521	NAB	Spacer, V-packing (see TB 108)	3
162	48363	D	48363	D	48363	D	Back-up-ring, seat	6
163	26142	NBR	26142	NBR	26142	NBR	O-ring, seat – 80D	6
	14330	FPM	14330	FPM	14330	FPM	O-ring, seat – 70D	6
	# 701493	EPDM	# 701493	EPDM	# 701493	EPDM	O-ring, seat	6
164	44727	S	44612	SS	44612	SS	Seat	6
166	43932	S	44108	SS	44108	SS	Valve	6
167	44109	SS	44109	SS	44109	SS	Spring	6
168	44728	PVDF	44728	PVDF	44728	PVDF	Retainer, spring	6
170	44729	SS	44729	SS	44729	SS	Washer, spring retainer	6
171	44644	SS	44644	SS	44644	SS	Coil spring (70 kg), valve plug	6
172	89827	NBR	89827	NBR	89827	NBR	O-ring, valve plug – 90D	6
	11747	FPM	11747	FPM	11747	FPM	O-ring, valve plug – 90D	6
	# 701494	EPDM	# 701494	EPDM	# 701494	EPDM	O-ring, valve plug – 70D	6
173	48364	D	48364	D	48364	D	Back-up-ring, valve plug	6
174	46444	FBB	49300	SSD	44643	NAB	Plug, valve	6
185	49465	BBCP R	49299	SSD	76335	NAB	Manifold, discharge (see TB 099 & 109)	1
188	89981	S	89981	S	89981	S	Screw, HSH (M12x70)	8
250	44516	NY	44516	NY	44516	NY	Protector, shaft w/2 screw, lockwashers, washer	1
255	34018	STZP R	34018	STZP R	34018	STZP R	Kit, direct mount	1
	34039	S	34039	S	34039	S	Kit, direct mount	1
260	92674	STZP R	92674	STZP R	92674	STZP R	Mounting, box assy (incl. 34018)	1
	-	-	76514	S	76514	S	Mounting, box assy (incl. 34039)	1
275	990013	STL	990013	STL	990013	STL	Hub “B” 35mm w/keyway (see TB 003)	1
278	80540	ZP	80540	ZP	80540	ZP	Screw, HH (M12x100) (rail adjusting screw)	1
279	30278	STZP	30278	STZP	30278	STZP	Oiler	3
283	34314	-	34314	-	34314	-	Kit, oil drain (3/8” x 48”)	1
299	818427	BBCP R	818372	SS	814522	NAB	Head, complete (models 3535,3531,3537 only)	1
300	31040	NBR*	31040	NBR*	31040	NBR*	Kit, seal (97,106,112,127,155,156) standard	1
	33055	FPM	33055	FPM	33055	FPM	Kit, seal (97,106,112,127,155,156)	1
	# 33262	EPDM*	# 33262	EPDM*	# 33262	EPDM*	Kit, seal (97,106,112,127,155,156)	1
310	34235	NBR	34017	NBR	34017	NBR	Kit, valve (162,163,164,166,167,168,170,172,173) standard	2
	31955	FPM	31955	FPM	31955	FPM	Kit, valve (162,163,164,166,167,168,170,172,173)	2
	# 31952	EPDM	# 31952	EPDM	# 31952	EPDM	Kit, valve (162,163,164,166,167,168,170,172,173)	2
-	819000	F	819000	F	819000	F	Assy, crankcase, cast iron conversion	1

Bold print part numbers are unique to a particular pump model. Italics are optional items. { } Date of latest production change.

silicone/grease required. + Production parts are different from service parts. R Components comply with RoHS directive. * Review material codes for individual items. See 'Tech Bulletins' 003, 024, 035, 036, 040, 041, 043, 050, 052, 053, 069, 074, 083, 095, 099, 105, 108 and 119 for additional information.

Material codes (not part or part number)

ABS	ABS plastic	FCM	Forged chrome-moly	SFG	Special blend FPM
AL	Aluminum	FPM	Fluorocarbon	SS	316 SS
BB	Brass	NAB	Nickel aluminum bronze	SSD	Duplex stainless steel
BBCP	Brass/chrome plated	NBR	Medium nitrile (Buna-N)	SSZZ	316 SS / zamak
CC	Ceramic	NBRS	Buna, silicone free	STCP	Steel / chrome plated
CM	Chrome-moly	NY	Nylon	STG	Special blend PTFE white
D	Acetal	PE	Polyethylene	STL	Steel
EPDM	Ethylene propylene diene mon.	POP	Polypropylene	STZP	Steel / zinc plated
F	Cast iron	PTFE	Pure polytetrafluoroethylene	TNM	Special high strength
FBB	Forged brass	PVDF	Polyvinylidene fluoride	ZP	Zinc plated
FBR	Fiber	S	304 SS		